

## INSTALLATION INSTRUCTIONS FOR SPARK IGNITION MODULE #037981

### For IFMs With Spark Ignition Module Mounted in the Blower Box

1. Remove blower box front cover from the cabinet. Remove blower box cover from the base plate exposing the obsolete dual electrode spark ignition module (Part # 019724) and the relight circuit box.

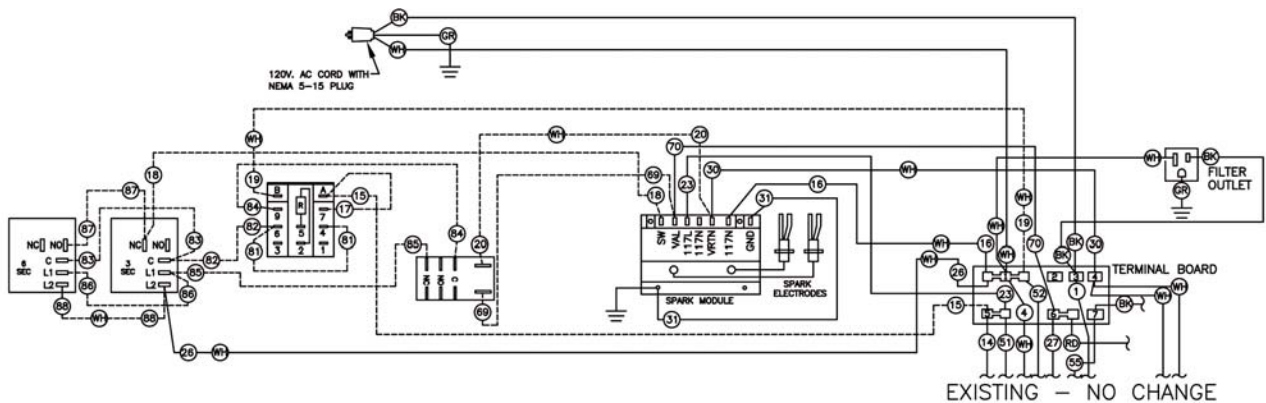

FIG 1. WIRING DIAGRAM FOR IFMs WITH DUAL-ELECTRODE SPARK IGNITION MODULE (PART # 019724) AND RELIGHT CIRCUIT

2. Locate wire # 16, 20, 18 and 69 between the old spark module and relight circuit. Disconnect and discard the wires. Discard the wire # 15 and 17 connected between the terminal board and relight circuit.
3. Disconnect wire # 16, 20, 23, 31, and 69 from the old spark module.
4. Locate the two spark ignition electrode leads connected between the dual-spark ignition module and the two burner electrode assemblies that are mounted behind the IFM's control panel back.
5. For gaining access to the two burner electrode assemblies, unscrew and remove the control panel followed by the control panel back. Unplug both ends of each of the spark ignition electrode leads, one end from the obsolete spark ignition module and the other end from the corresponding burner electrode assembly. Discard the two unplugged spark ignition electrode leads.
6. The dual-electrode obsolete spark ignition module is totally disconnected from the IFM circuit. Unscrew and discard the module. Also disconnect the wire # 19 from the relight circuit. Unscrew the relight circuit box and discard it.

# SERVICE INSTRUCTIONS

www.keatingofchicago.com

**KEATING**  
OF CHICAGO, INC.®

Part # 037983

1-800-KEATING

## INSTALLATION INSTRUCTIONS FOR SPARK IGNITION MODULE #037981

For IFMs With Spark Ignition Module Mounted in the Blower Box

7. Drill holes and mount the two new modules (Part # 037978) keeping in mind the length of the new spark electrode leads (length: 24", Part # 037551) and the space occupied by the two modules. Use pan head screws # 8-32 x 3/4", # 8-32 hex nuts and internal tooth lock washers #8.

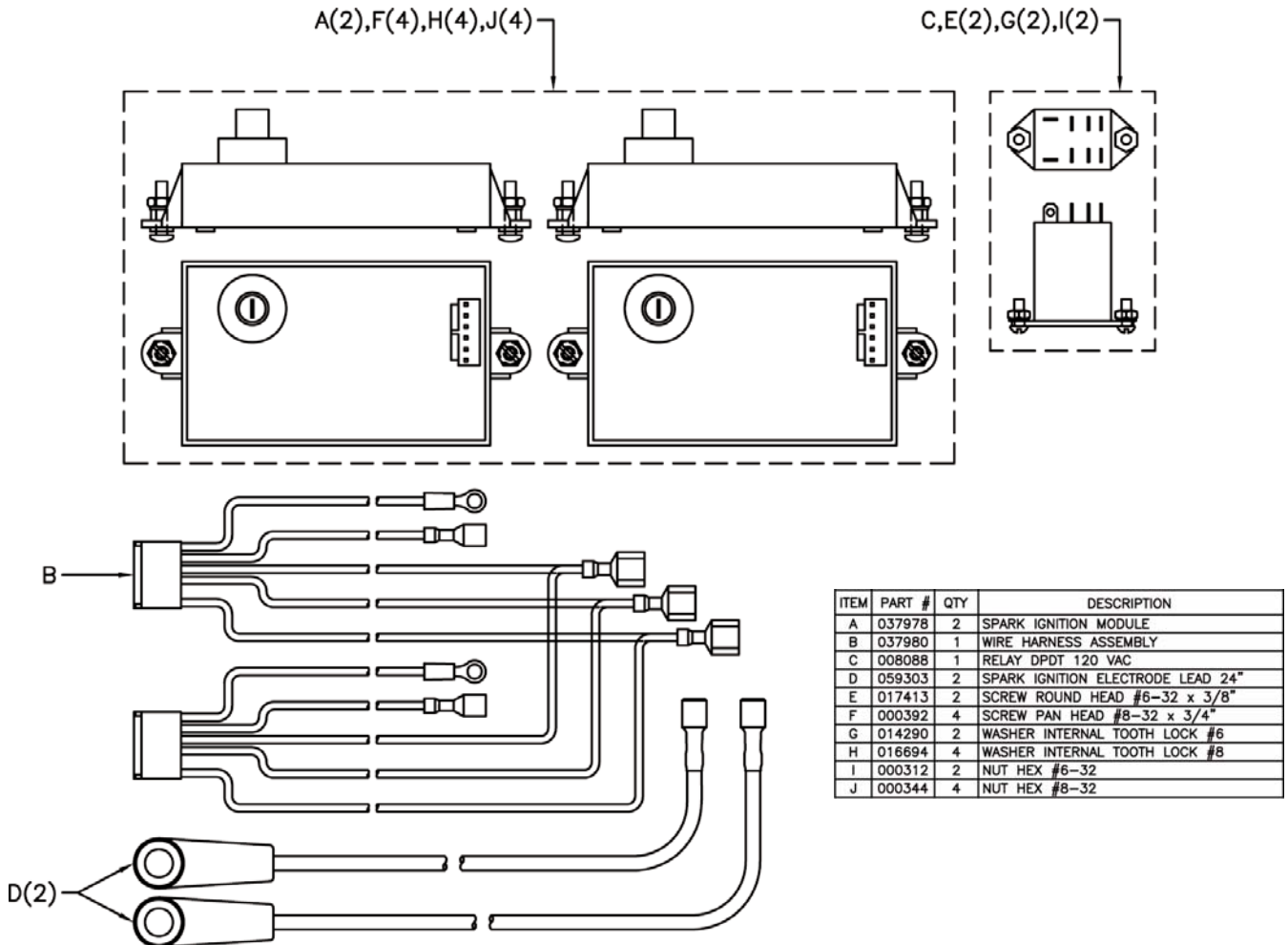

# SERVICE INSTRUCTIONS

www.keatingofchicago.com

**KEATING**  
OF CHICAGO, INC.®

Part # 037983

1-800-KEATING

## INSTALLATION INSTRUCTIONS FOR SPARK IGNITION MODULE #037981

### For IFMs With Spark Ignition Module Mounted in the Blower Box

8. Drill holes and mount the 120V AC DPDT relay with round head screws # 6-32 x 3/8", # 6-32 hex nuts and internal tooth lock washers #6. The location should be in accordance with the two new modules and the length of the wires on the wire harness.

9. Make connections between the two modules by installing the supplied wire harness. Refer to Fig. 2 below for detailed wiring. Dashed lines in Fig. 2 show the removed and discarded wires. Dashed lines in Fig. 3 below show the added/rewired connections. Solid lines show unaltered wiring in both Fig. 2 and 3.

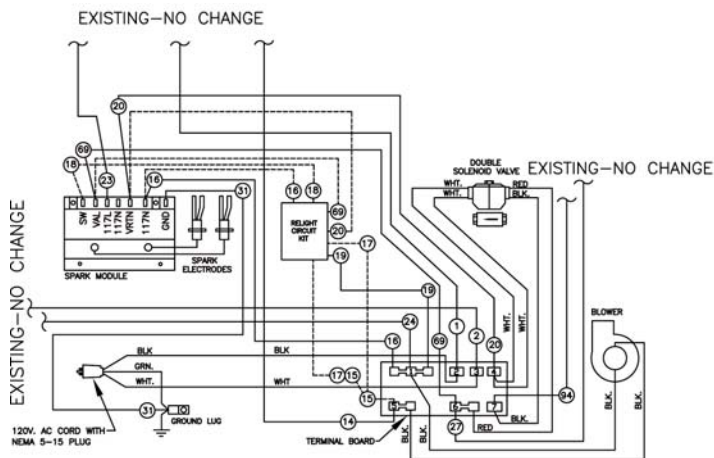

FIG 2. WIRING DIAGRAM FOR IFMS WITH DUAL-ELECTRODE SPARK IGNITION MODULE (PART # 019724) AND RELIGHT CIRCUIT KIT

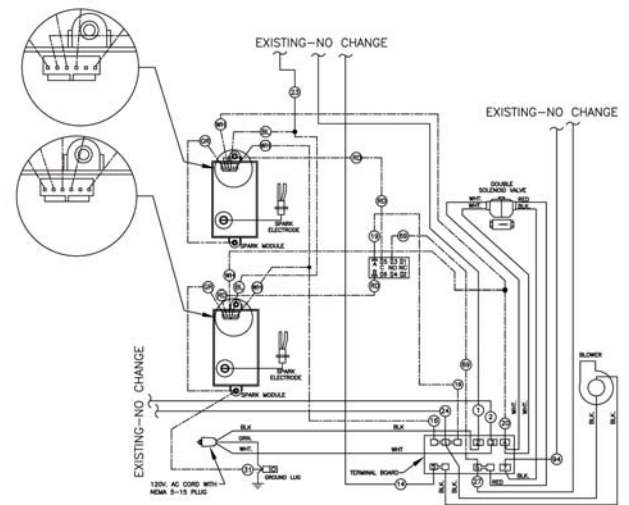

FIG 3. WIRING DIAGRAM FOR IFMS WITH TWO SINGLE-ELECTRODE SPARK IGNITION MODULES (REPLACEMENT, PART # 037978) AND 120VAC DPDT RELAY (PART # 008088)

10. Connect the 1/4" quick disconnect end of the new spark electrode lead (Part # 037551) to the male tab of the single-electrode spark ignition module. Take the other end of the lead to the burner electrode assembly behind the IFM's control panel back. Repeat the same procedure for the other spark electrode lead. Secure the connections.

11. Re-attach the control panel back followed by the control panel. Screw the blower box cover to the base plate and re-assemble all the components.